

Case Study

OP 483 – WATCHMAKING AT THE FRONTIERS OF PERFECTION

DESIGNED FOR THOSE WHO DEFY LIMITS



ABOUT OSKAR PASCAL



Oskar Pascal is a watch company with a passion for extreme materials and innovative micro-technology. Swedish brothers Jakob and Petter Paulin develop and design watches in Stockholm in close collaboration with one of the world's most renowned watchmakers, Cyrano Devanthey. Uncompromising perfection is the motivation of both brothers and Devanthey. Once designed, the watches are manufactured in Fleurier, La Chaux-de-Fonds and Geneva in Switzerland to ensure the high quality and craftsmanship that characterizes every Oskar Pascal product.

The name Oskar Pascal is a combination of Jacob's middle name Oskar and Pascal, the unit for pressure and mechanical tension. A tribute to the unique quality and strength of the material.

TACKLING CHALLENGES

Oskar Pascal was looking for an exceptional material that would protect the sensitive precision of micromechanics in particular. It had to have high strength and high hardness and be usable in detail within tight tolerances. In addition, Oskar Pascal manufactures watches that are expected to last a very long time and must therefore be very durable and wear resistant.

The solution was found with the choice of the amorphous alloy AMLOY-ZR01 for so-called blanks and sleeves of the watch cases. The blanks are printed by selective laser melting (SLM) in 720 layers and passed to a precision CNC machining and polishing operation for final contouring. This unique value chain made it possible to realize the ambitious designs of the Paulin brothers.

AMORPHOUS ALLOYS IMPROVING WATCHMAKING

With the extraordinary material class of amorphous alloys, high-end watches can completely redesign their uniqueness. The most sensitive technologies in miniaturized space are efficiently protected and the design of housings and features can be perfected.

Due to their biocompatibility, watch components made of amorphous metals are not only highly corrosion-resistant, but also antibacterial, and their low thermal conductivity and high surface quality enable pleasant contact with the skin. Functional advantages also result from the high storage capacity of elastic energy ($> 14 \text{ J/m}^3$), the high strength ($> 1.6 \text{ GPa}$ tensile strength) and the possibilities of precise near-net-shape manufacturing.



CHALLENGES

After decades of experience in various fields, Jakob turned to Petter with his idea of making unique and durable watches. Oskar Pascal was born with a clear vision of the strength of a process where design and technical development are seamless and parallel. One of the biggest challenges was finding the right material for their unique watch system that would allow the two brothers to achieve their goal of perfection. In particular, the case and their new pod technology had to be as robust and scratch-resistant as possible.

At the same time, it also had to be as exclusive and durable as possible. Conventional materials in conventional processes were therefore out of the question for Petter's and Jakob's ideas and implementation wishes.

They therefore compared the state of the art in materials and manufacturing processes for watch cases with each other and set out to find above-average possibilities in material and manufacturing technologies that were appropriate to their quest for design freedom.

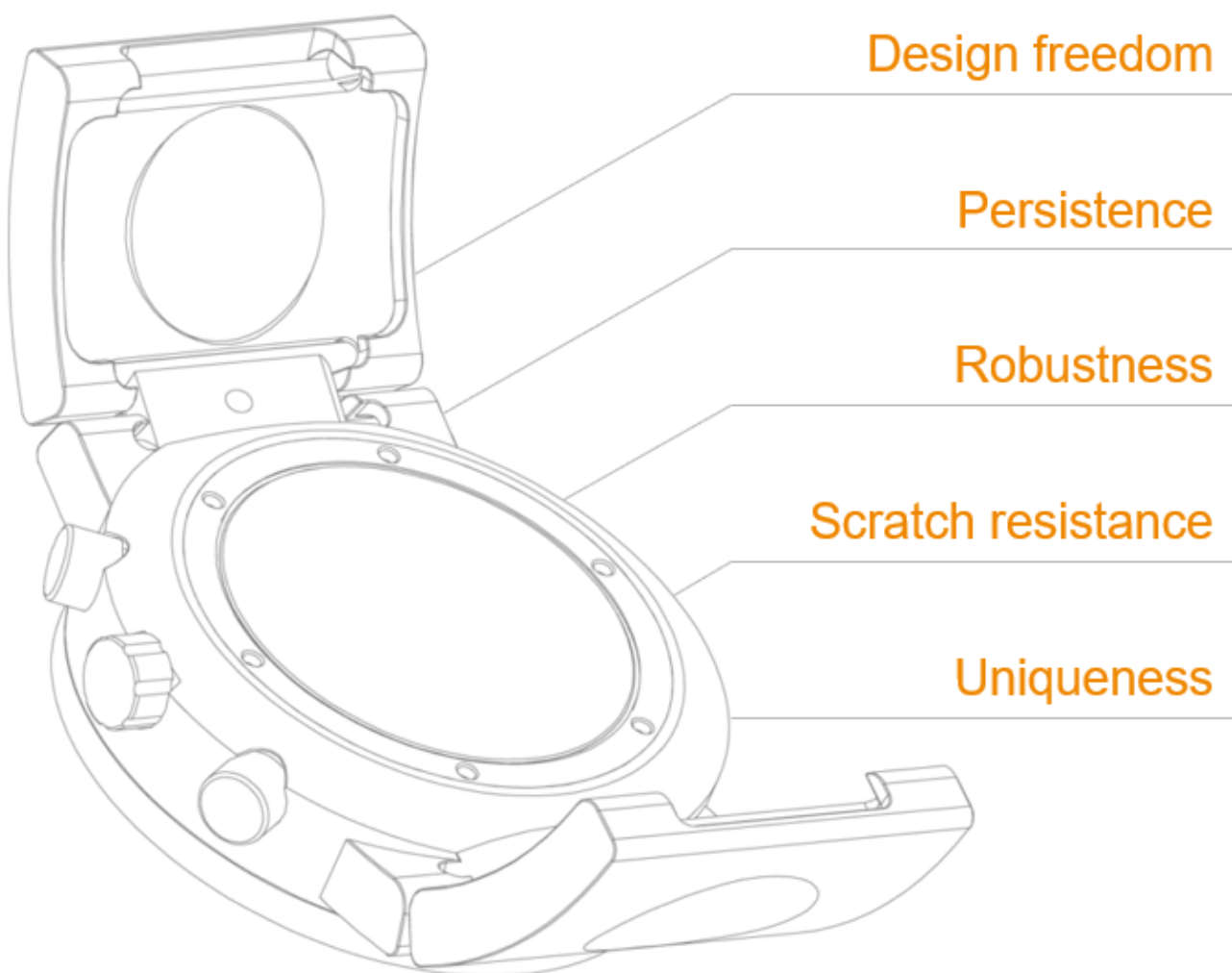

SOLUTION

Through the unique production of metallic glasses, as the amorphous alloys are also called, Heraeus AMLOY has succeeded in meeting the high mechanical requirements of the Paulin brothers with amorphous components made of AMLOY-ZR01. Through the use of additive manufacturing and the resulting freedom of design in production, these were even surpassed.

The zirconium-based alloy AMLOY-ZR01 is ideally suited for processing in 3D printing using the SLM process. Complex geometries and even large component dimensions are realized through isotropic material behavior. The material is characterized within the AMLOY alloy series by its good ductility. Additive manufacturing of amorphous metals can be used to produce both individual components and specific surface structures with exceptional properties:



Corrosion resistance



Strength



Durability



Unique material



Hardness



Wear resistance

Heraeus AMLOY produces the base material of the amorphous alloy AMLOY-ZR01 and the atomized powder is applied layer by layer by means of SLM production equipment. Two laser beams with a power of up to 200 W and a focus of approx. 55µm then scan the contour of the component per powder layer.

To obtain an amorphous state of the component, the parameters must be selected so that the temperature in the powder bed is below the critical crystallization temperature of the alloy. In this way, it is possible to perpetuate the exceptional properties of the alloy in the components of the watch. The printed blanks are then CNC finished and polished several times for a luxurious finish.



RESULT

The result of the Paulin brothers' high-end watch is unique in many ways. Not only did they develop a revolutionary design, but with their unique pod system as well as the use of the new and superior material class of amorphous metals, they are creating a new opportunity to set new standards in the watch industry.

Likewise, there are already the first ideas of functional components, which include not only the strength but also the elasticity of the material, which is up to 10 times higher than conventional stainless steel alloys, and thus allow not only the robustness but also a functional movement or damping. Looking at other potential components in the exciting environment of high-end watch segments, it can be used to efficiently produce bezels, bracelet pins, clasps, cases as well as shock-absorbing safety elements.

Oskar Pascal has demonstrated impressively and to perfection how quickly and easily new technologies can be adopted and used to overcome challenges.



” We are simply not an average watch.
Petter Paulin, CEO Oskar Pascal

START YOUR AMORPHOUS JOURNEY NOW

About Heraeus

Heraeus, the technology group headquartered in Hanau, Germany, is a leading international family-owned portfolio company. The company's roots go back to a family pharmacy started in 1660. Today, the Heraeus group includes businesses in the environmental, electronics, health and industrial applications sectors. Customers benefit from innovative technologies and solutions based on broad materials expertise and technological leadership.

In the 2020 financial year, the FORTUNE Global 500 listed group generated revenues of €31.5 billion with approximately 14,800 employees in 40 countries. Heraeus is one of the top 10 family-owned companies in Germany and holds a leading position in its global markets.

About Heraeus AMLOY

Heraeus AMLOY specializes in the development of amorphous alloys and the production of amorphous components. These enable completely new high-tech applications due to their unique material properties such as high strength combined with high elasticity as well as corrosion resistance and biocompatibility.

Heraeus AMLOY's near-net-shape process solutions injection molding and 3D printing are ideally suited for industrial production

amloy@heraeus.com | +49 (6181) 35-9650 | www.heraeus-amloy.com

